

TANAI/PNEUMATICS

GRIPPERS STANDARD DIMMENSIONS

☞ DIMENSION

MODEL NO. HPS-16W

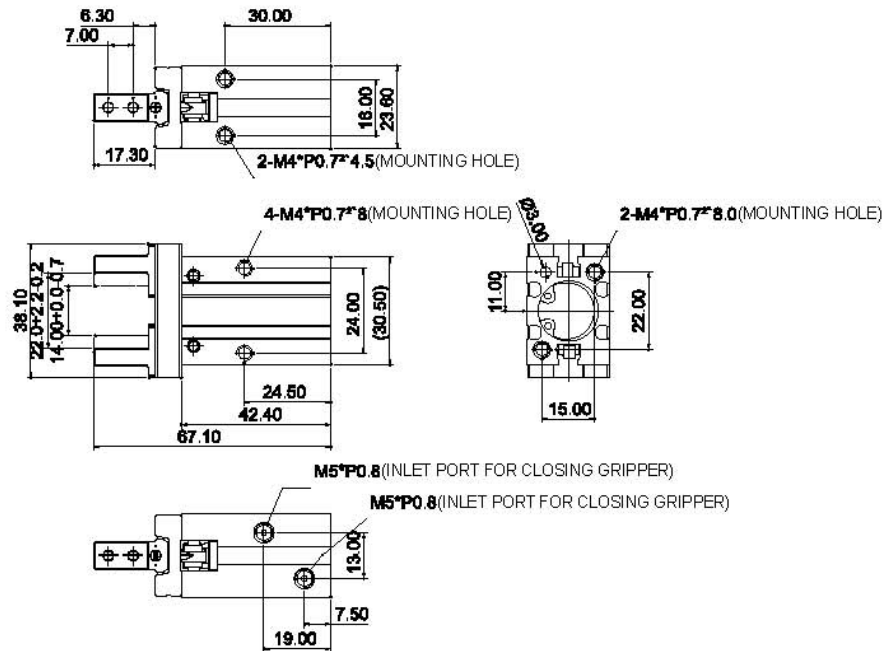

MODEL NO. HPS-16N

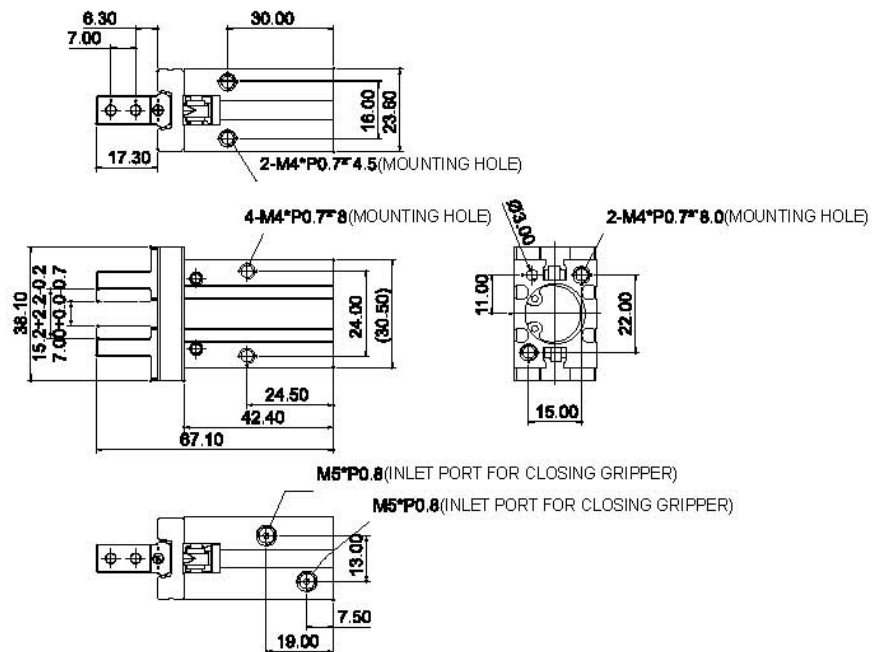

TAN AIR PNEUMATICS

GRIPPERS STANDARD DIMMENSIONS

↔ DIMENSION

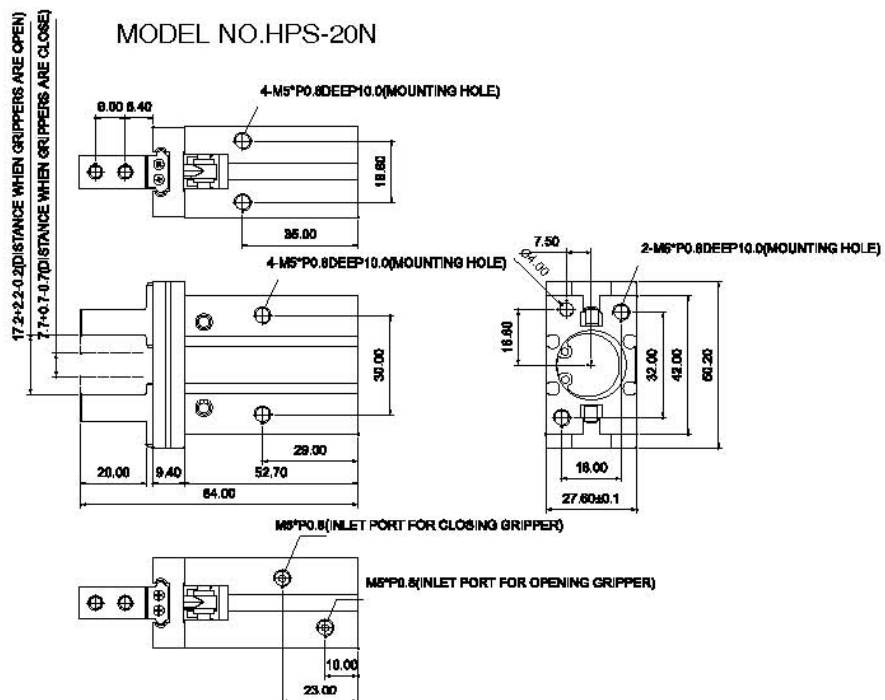
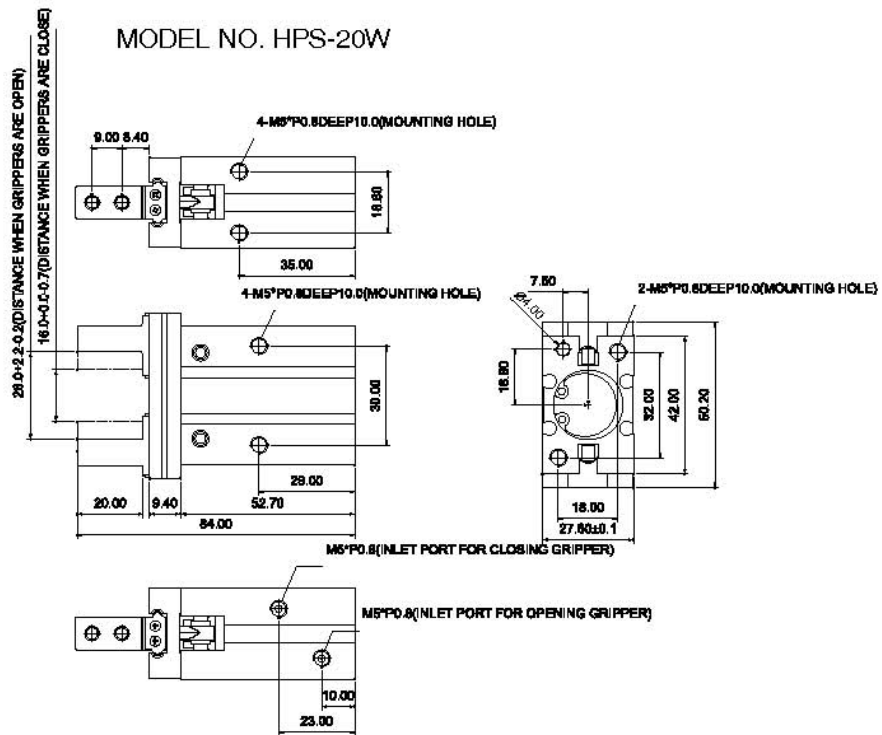

TANAIR PNEUMATICS

GRIPPERS STANDARD DIMMENSIONS

↻ DIMENSION

MODEL NO. HYS-16

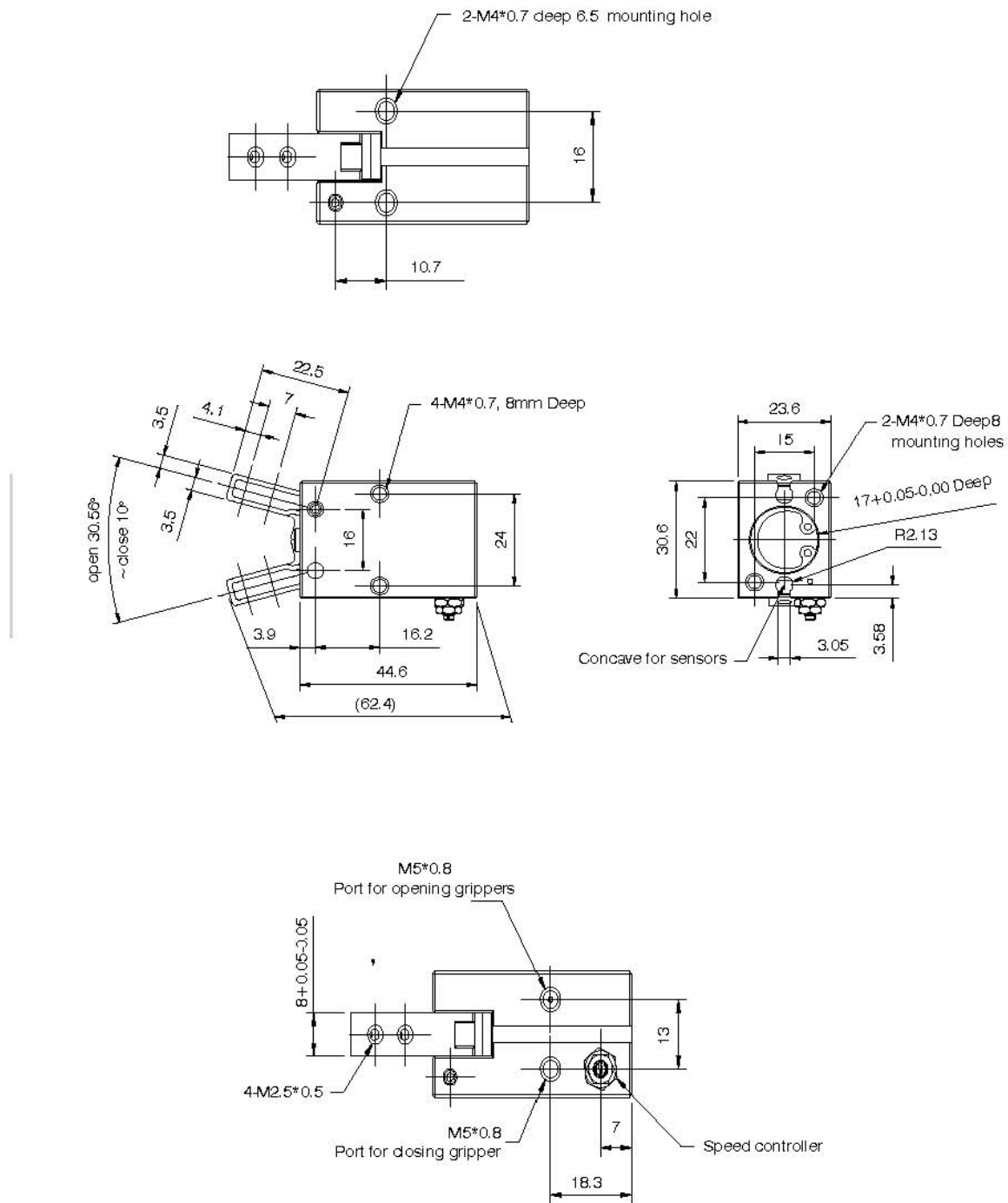

TANAIR PNEUMATICS

GRIPPERS STANDARD DIMMENSIONS

↻ DIMENSION

MODEL NO. HYS-20

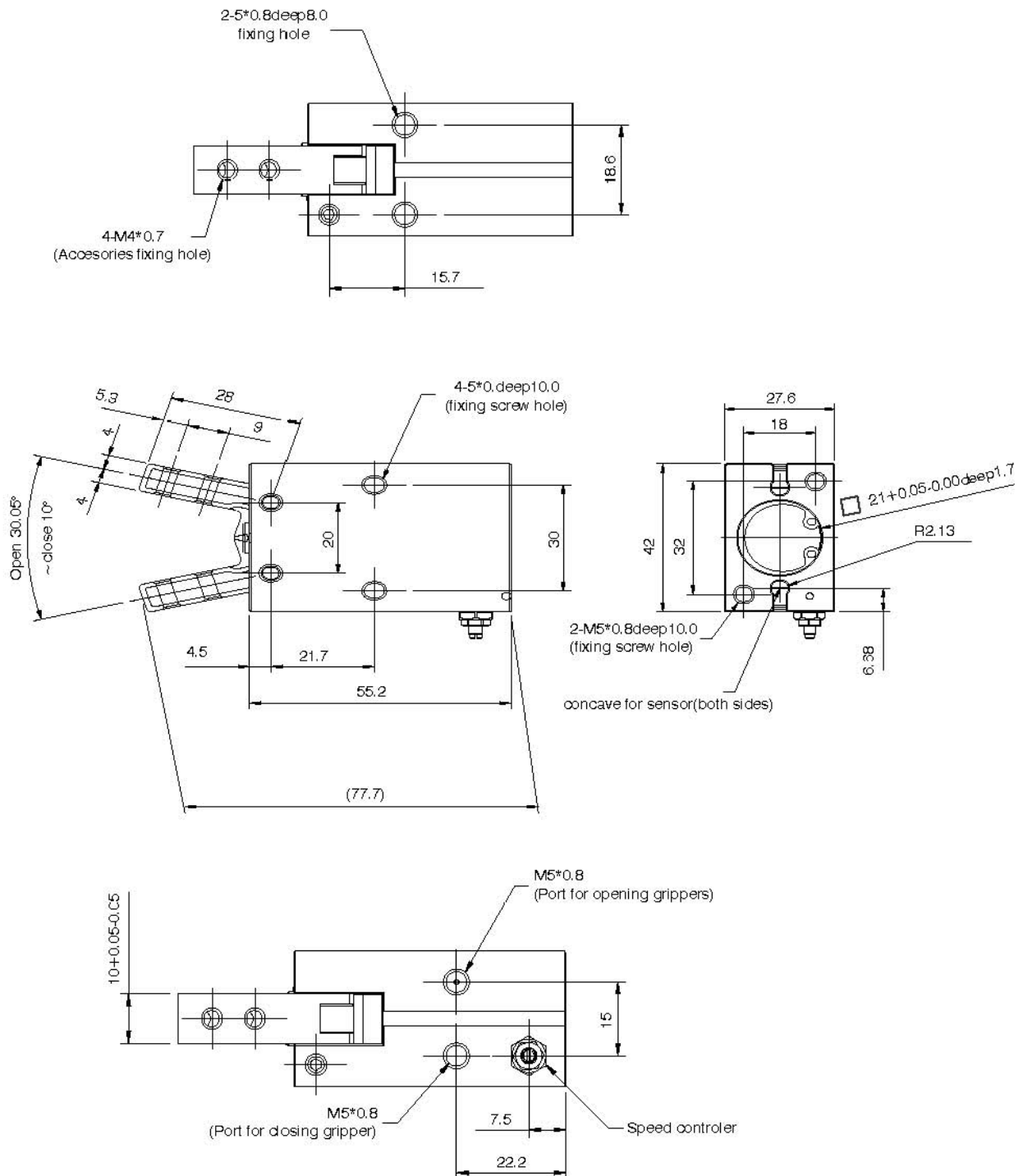

TANAI R PNEUMATICS

GRIPPERS STANDARD DIMMENSIONS

⊙ → DIMENSION

- Fulcrum type

● HYC-10 Bore \varnothing 10

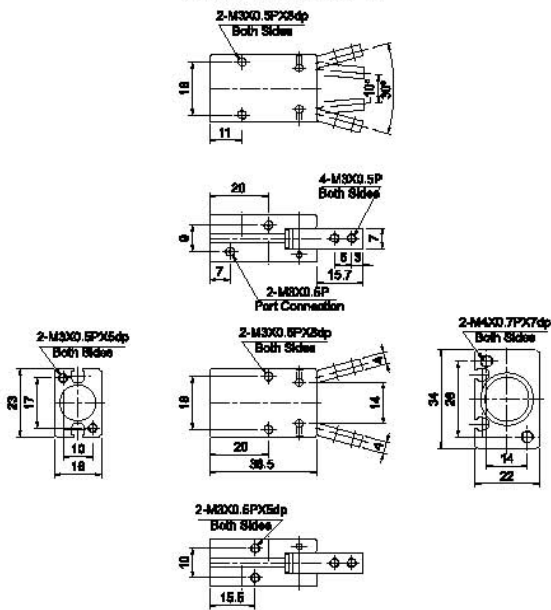

● HYC-16 Bore \varnothing 16

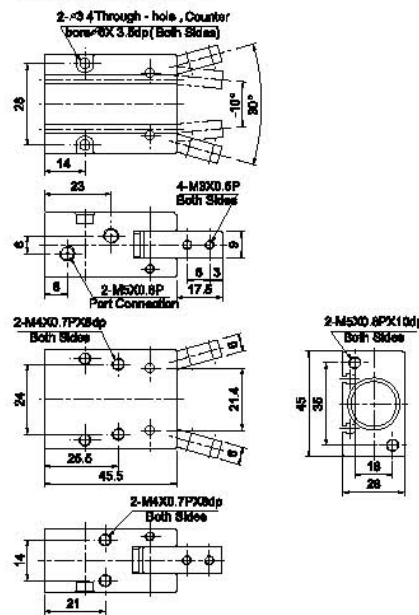

● HYC-20 Bore \varnothing 20

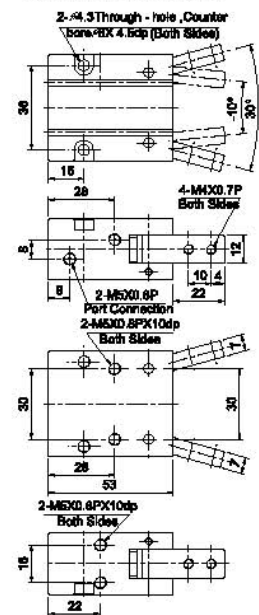

● HYC-25 Bore \varnothing 25

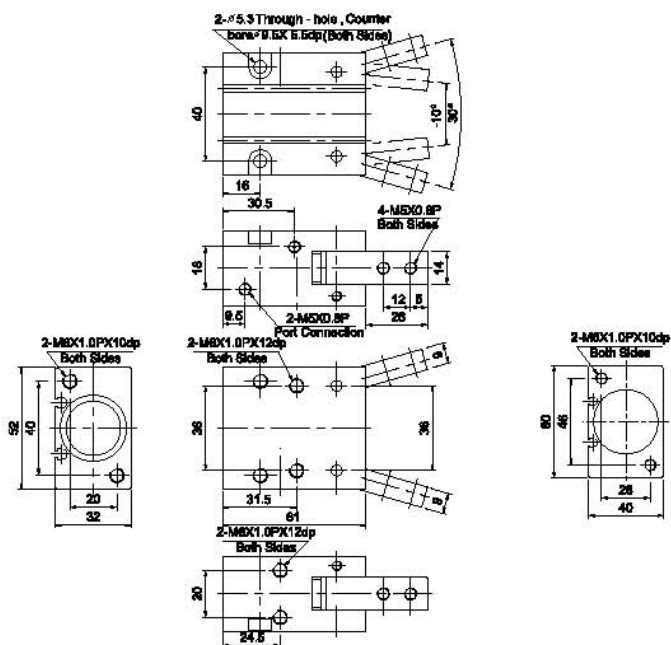

● HYC-32 Bore \varnothing 32

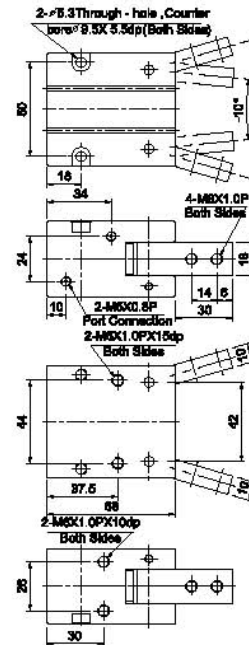

TANAIR PNEUMATICS

GRIPPERS STANDARD DIMMENSIONS

⑥ → DIMENSION

● PARALLEL TYPE

● HPC-10 Bore Ø 10

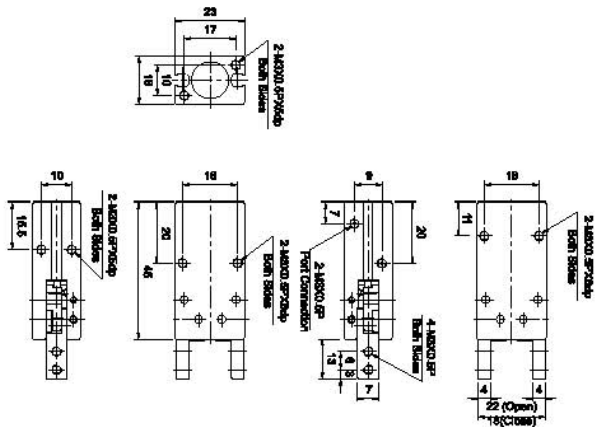

● HPC-16 Bore Ø 16

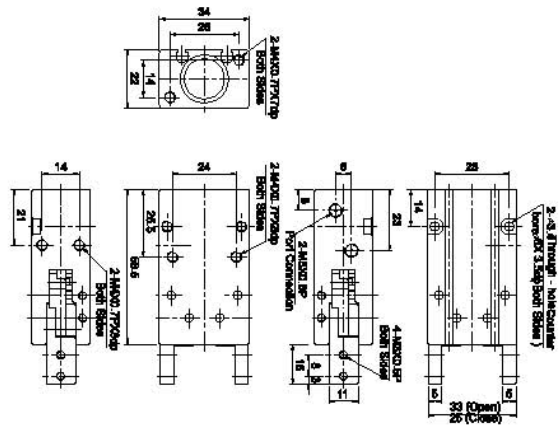

● HPC-25 Bore Ø 25

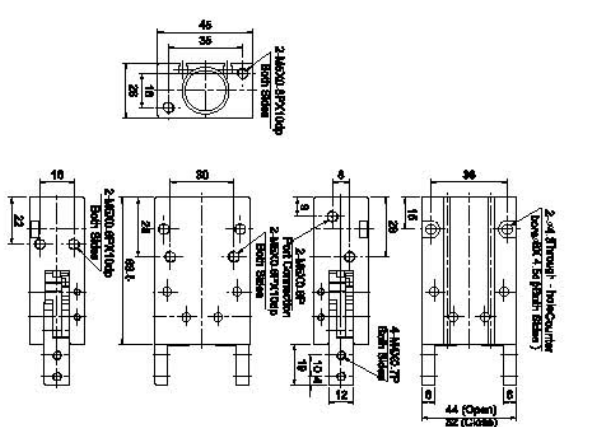

● HPC-20 Bore Ø 20

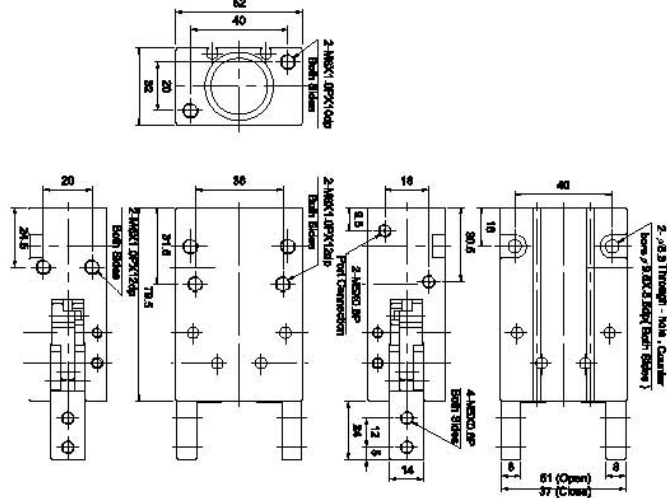

● HPC-32 Bore Ø 32

