

TAN AIR PNEUMATICS

PTFE VALVE

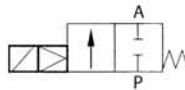

☉ SYMBOL



☉ FEATURES

- Direct acting, fast response.
- Suitable for acid or alkaline chemical fluid.
- Fluid always in liquid status.
- Installed horizontally

☉ SPECIFICATION

MODEL	PE220-03	PE220-04
Port size	3/8"	1/2"
Fluid	Pure water, chemical acid	
Orifice	5mm	
Operation	Direct acting	
Diaphragm	NBR with Teflon laminated outside	
Pressure range	0.1 ~ 1 kgf/cm ²	
Max. pressure	1kgf/cm ²	
Body material	Teflon	
Temperature range	-5 °C ~ 90 °C	
Ambient temperature	-20 °C ~ 60 °C	
Installation	Horizontally	
Duty cycle	100% ED	
Coil type	Din	
Protection deg.	IP65 (DIN 40 050)	
Insulation	F	
Voltage tolerance	± 10%	
Standard voltage	220VAC, 110VAC, 24VDC	
Power consumption	22VA(AC 50Hz), 15W (DC)	
Net weight	1660g	1660g

☉ DIMENSIONS

• PE 220-03

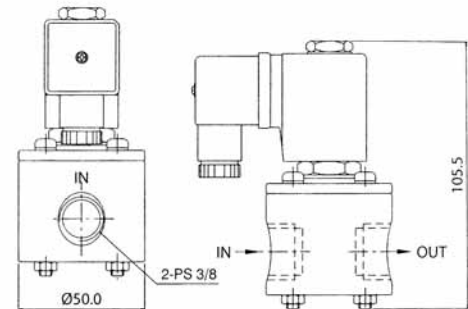

• PE 220-04

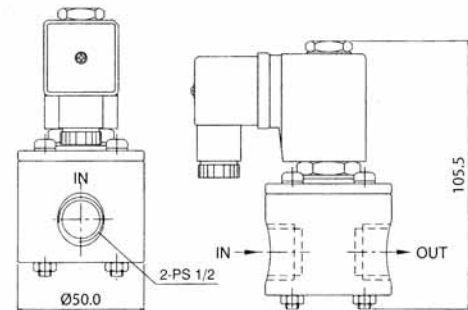

☉ HOW TO ORDER

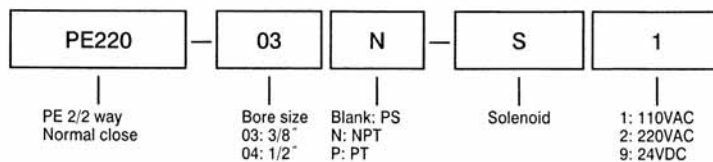

Please contact us if you need other voltage or ex-proof coil.