

# TAN AIR PNEUMATICS

## TPCQ2(NON MAGNETIC) CYLINDER PARTS ORDERING GUIDE

### ORDERING GUIDE

### HOW TO ORDER

TPCQ2



BASIC - No Mount

B - FOOT Mount

A - TAPPED MOUNTING HOLES

\*W - THROUGH ROD TYPE

\*SJ - STROKE ADJUSTABLE TYPE

\*TS - BACK TO BACK TYPE



N -NON LUBE TYPE  
STANDARD

H -HYDRAULIC TYPE

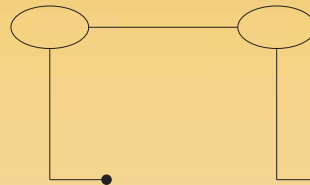

BORE

12mm,16mm

20mm,25mm

32mm,40mm

50mm,63mm

80mm,100mm

STROKE

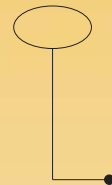

PISTON ROD  
THREAD OPTIONS

Blank:Female Thread

M:Male Thread

### NOTE

1.FOR DIMENSIONS SEE STANDARD DIMENSIONS PDF

2.FOR \*TYPE DIMENSIONS SEE NON STANDARD PDF

3.FOR ANY OPTIONS NOT LISTED CONTACT TAN AIR

4\*SEE DIMENSIONS PDF FOR NON STANDARD DIMENSIONS

# TAN AIR PNEUMATICS

## TPCQ2(NON MAGNETIC) COMPACT CYLINDER DOUBLE ACTING TYPE

Female Screw:  $\Phi 12$ — $\Phi 25$

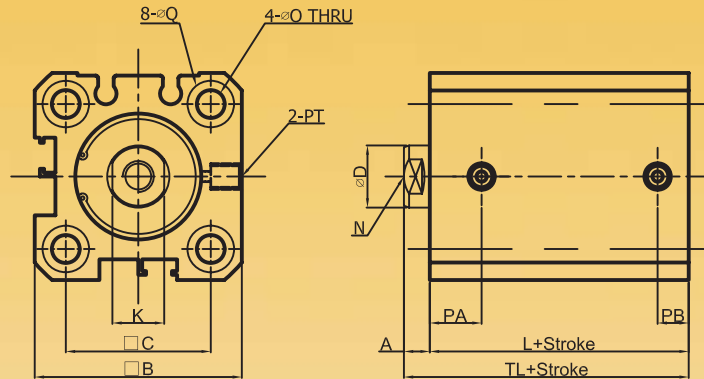

Male Screw:  $\Phi 12$ — $\Phi 25$

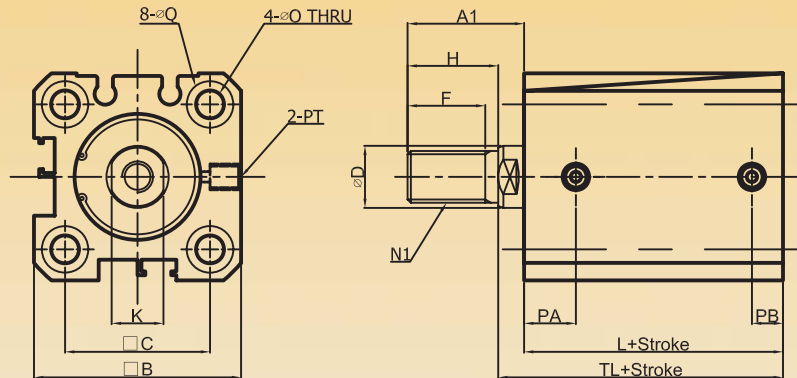

Model	Stroke	A	A1	□B	□C	$\Phi D$	F	H	K	L	N	N1	$\Phi O$	PA
TPCQ2B12	5~30	3.5	14	25	19.5	6	9	10.5	5	17	M3×0.5 Dp6	M5×0.8	3.5	7.5
TPCQ2B16	5~30	3.5	15.5	29	20	8	10	12	6	18.5	M4×0.7 Dp8	M6×1.0	3.5	8
TPCQ2B20	5~50	4.5	18.5	36	25.5	10	12	14	8	19.5	M5×0.8 Dp8	M8×1.25	5.5	10.5
TPCQ2B25	5~50	5	22.5	40	28	12	15	17.5	10	22.5	M6×1.0 Dp12	M10×1.25	5.5	11

Model	PB	TL	PT	$\Phi Q$
TPCQ2B12	5	20.5	M5×0.8	6.5 Dp3.5
TPCQ2B16	5.5	22	M5×0.8	6.5 Dp3.5
TPCQ2B20	6	24	M5×0.8	9 Dp7
TPCQ2B25	5.5	27.5	M5×0.8	9 Dp7

### Both End-Tap Type

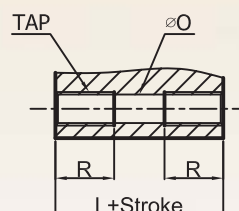

Model	TAP	R
TPCQ2B12	M4×0.7	7
TPCQ2B16	M4×0.7	7
TPCQ2B20	M6×1.0	10
TPCQ2B25	M6×1.0	10

# TAN AIR PNEUMATICS

## TPCQ2(NON MAGNETIC) COMPACT CYLINDER DOUBLE ACTING TYPE

Female Screw:  $\Phi 32$ — $\Phi 100$

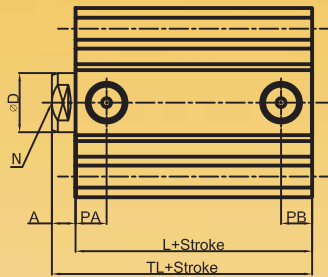
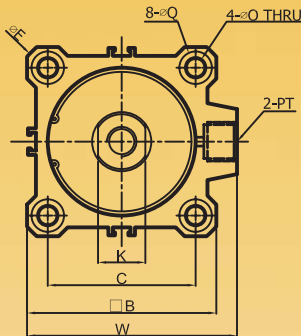

Male Screw:  $\Phi 32$ — $\Phi 100$

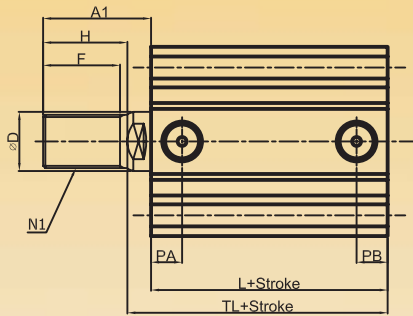
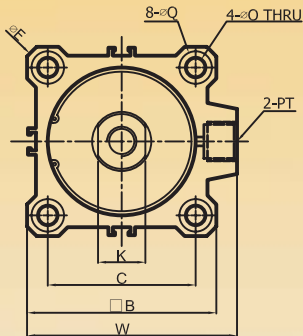

Both End-Tap Type

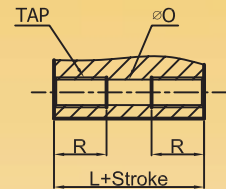

Model	TAP	R
TPCQ2B32	M6×1.0	10
TPCQ2B40	M6×1.0	10
TPCQ2B50	M8×1.25	14
TPCQ2B63	M10×1.5	18
TPCQ2B80	M12×1.75	22
TPCQ2B100	M12×1.75	22

Model	Stroke	A	A1	□B	□C	ΦD	ΦE	F	H	K	L	N	N1
TPCQ2B32	5	7	28.5	45	34	16	60	20.5	23.5	14	23	M8×1.25 Dp13	M14×1.5
	10~100												
TPCQ2B40	5~100	7	28.5	52	40	16	69	20.5	23.5	14	29.5	M8×1.25 Dp13	M18×1.5
TPCQ2B50	10~100	8	33.5	64	50	20	86	26	28.5	16	30.5	M10×1.5 Dp15	M18×1.5
TPCQ2B63	10~100	8	33.5	77	60	20	103	26	28.5	16	36	M10×1.5 Dp15	M18×1.5
TPCQ2B80	10~100	10	43.5	98	77	25	132	32.5	35.5	22	43.5	M16×2.0 Dp21	M22×1.5
TPCQ2B100	10~100	12	43.5	117	94	30	156	32.5	35.5	27	53	M20×2.5 Dp27	M26×1.5

Model	ΦO	PA	PB	TL	PT	ΦQ	W
TPCQ2B32	5.5	11.5	5.5	30	M5×0.8	9 Dp7	49.5
		10.5	7.5		PT1/8		
TPCQ2B40	5.5	12	8.5	36.5	PT1/8	9 Dp7	57
TPCQ2B50	6.8	10.5	10.5	38.5	PT1/4	11 Dp8	71
TPCQ2B63	9	15	11	44	PT1/4	14 Dp10.5	84
TPCQ2B80	11	18	12.5	53.5	PT3/8	17.5 Dp13.5	104
TPCQ2B100	11	23	13	65	PT3/8	17.5 Dp13.5	123.5

# TAN AIR PNEUMATICS

## TPCQ2(NON MAGNETIC) COMPACT CYLINDER DOUBLE ACTING TYPE

Female Screw:  $\Phi 20$ — $\Phi 25$

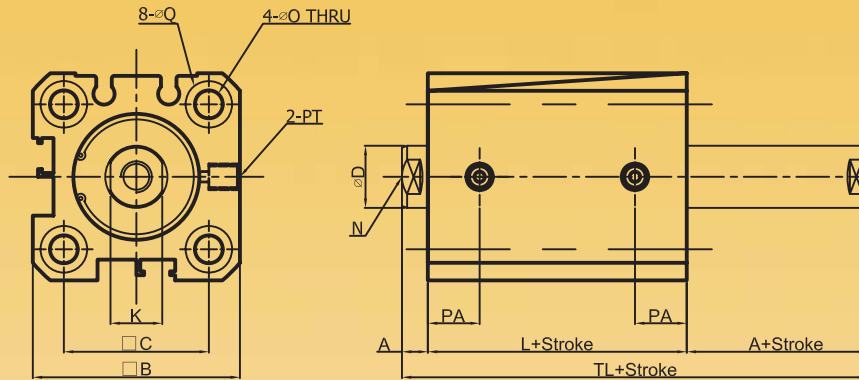

Male Screw:  $\Phi 20$ — $\Phi 25$

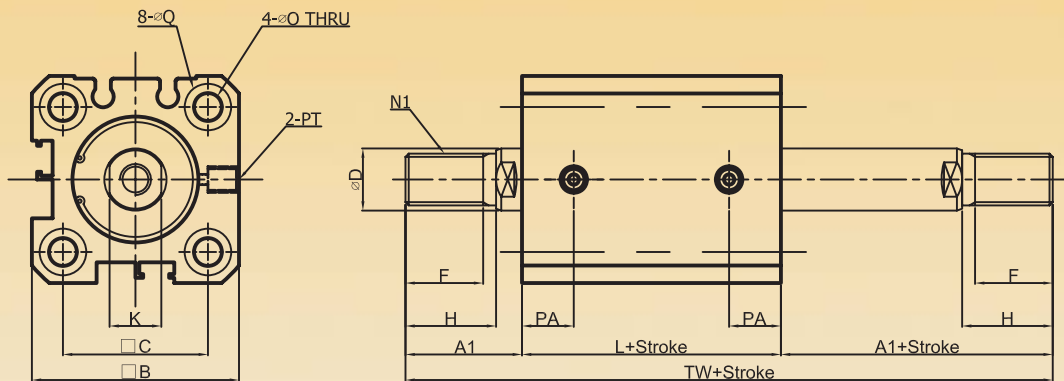

Model	Stroke	A	A1	□B	□C	$\Phi D$	F	H	K	L	N	N1	$\Phi O$	PA
TPCQ2B20	5~50	4.5	18.5	36	25.5	10	12	14	8	26	M5×0.8 Dp8	M8×1.25	5.5	10.5
TPCQ2B25	5~50	5	22.5	40	28	12	15	17.5	10	29	M6×1.0 Dp12	M10×1.25	5.5	11

Model	TW	TL	PT	$\Phi Q$
TPCQ2B20	63	35	M5×0.8	9 Dp7
TPCQ2B25	74	39	M5×0.8	9 Dp7

### Both End-Tap Type

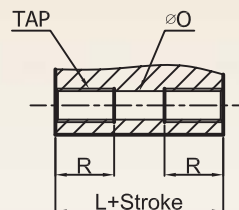

Model	TAP	R
TPCQ2B20	M6×1.0	10
TPCQ2B25	M6×1.0	10

# TAN AIR PNEUMATICS

## TPCQ2(NON MAGNETIC) COMPACT CYLINDER DOUBLE ACTING TYPE

Female Screw:  $\Phi 32$ — $\Phi 100$

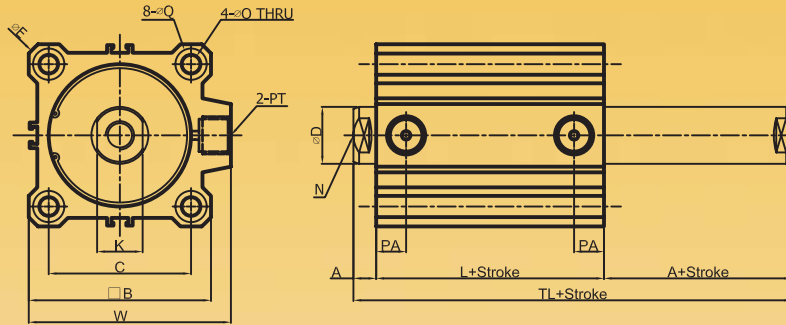

Male Screw:  $\Phi 32$ — $\Phi 100$

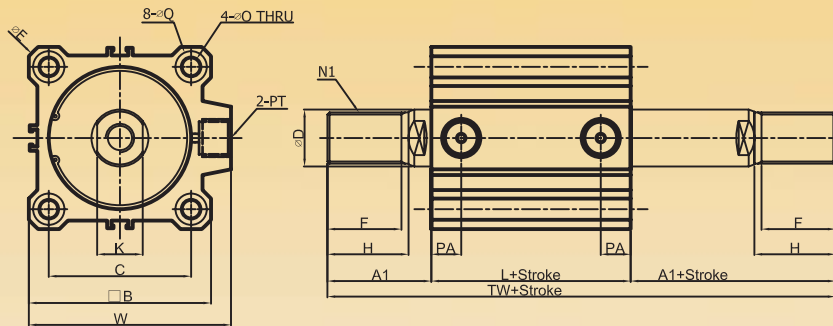

Both End-Tap Type

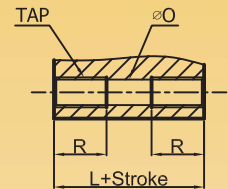

Model	TAP	R
TPCQ2B32	M6×1.0	10
TPCQ2B40	M6×1.0	10
TPCQ2B50	M8×1.25	14
TPCQ2B63	M10×1.5	18
TPCQ2B80	M12×1.75	22
TPCQ2B100	M12×1.75	22

Model	Stroke	A	A1	□B	□C	$\Phi D$	$\Phi E$	F	H	K	L	N	N1
TPCQ2B32	5	7	28.5	45	34	16	60	20.5	23.5	14	30.5	M8×1.25 Dp13	M14×1.5
	10~100												
TPCQ2B40	5~100	7	28.5	52	40	16	69	20.5	23.5	14	40	M8×1.25 Dp13	M18×1.5
TPCQ2B50	10~100	8	33.5	64	50	20	86	26	28.5	16	40.5	M10×1.5 Dp15	M18×1.5
TPCQ2B63	10~100	8	33.5	77	60	20	103	26	28.5	16	42	M10×1.5 Dp15	M18×1.5
TPCQ2B80	10~100	10	43.5	98	77	25	132	32.5	35.5	22	51	M16×2.0 Dp21	M22×1.5
TPCQ2B100	10~100	12	43.5	117	94	30	156	32.5	35.5	27	60.5	M20×2.5 Dp27	M26×1.5

Model	$\Phi O$	PA	TL	PT	$\Phi Q$	W
TPCQ2B32	5.5	11.5	44.5	M5×0.8	9 Dp7	87.5
		10.5		PT1/8		
TPCQ2B40	5.5	12	54	PT1/8	9 Dp7	97
TPCQ2B50	6.8	10.5	56.5	PT1/4	11 Dp8	107.5
TPCQ2B63	9	15	58	PT1/4	14 Dp10.5	109
TPCQ2B80	11	18	71	PT3/8	17.5 Dp13.5	138
TPCQ2B100	11	23	84.5	PT3/8	17.5 Dp13.5	147.5

# TAN AIR PNEUMATICS

## TPCQ2(NON MAGNETIC) COMPACT CYLINDER VARIABLE STROKE CYLINDER TYPE/CONTROL TYPE OF FORWARD MOTION SJ

Female Screw:  $\Phi 20$ — $\Phi 100$

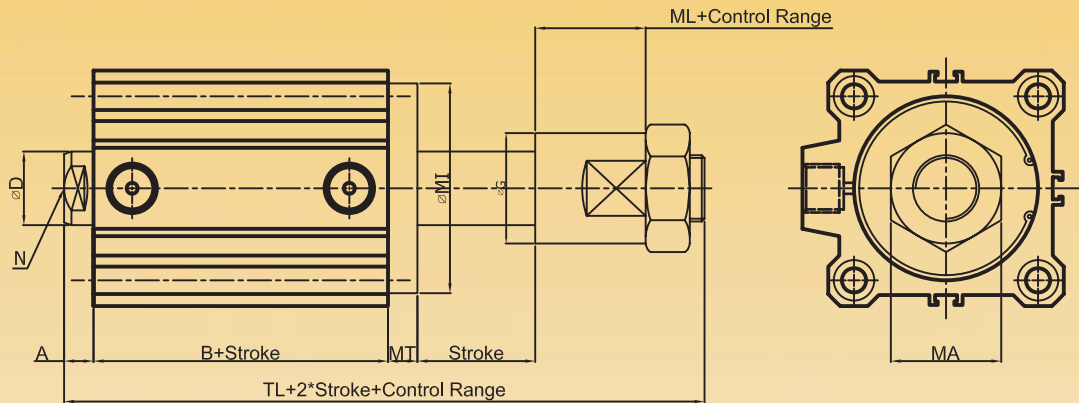

Bore	A	B	TL	MT	MI	MA	MK	ML	$\Phi G$
20	4.5	26	61	8	$\square 36$	17	10	12.5	20
25	5	29	64.5	8	$\square 40$	17	10	12.5	20
32	7	30.5	72.5	6	$\Phi 38$	24	14	16	27
40	7	40	82	6	$\Phi 46$	24	14	16	27
50	8	40.5	91.5	8	$\Phi 57$	30	16	20	35
63	8	42	95	10	$\Phi 68$	30	16	20	35
80	10	51	119	12	$\Phi 90$	41	20	28	48
100	12	60.5	134.5	14	$\Phi 100$	41	20	28	48