

# TAN AIR PNEUMATICS

## TPCS1 J.I.S TYPE CYLINDER

### BASIC TYPE

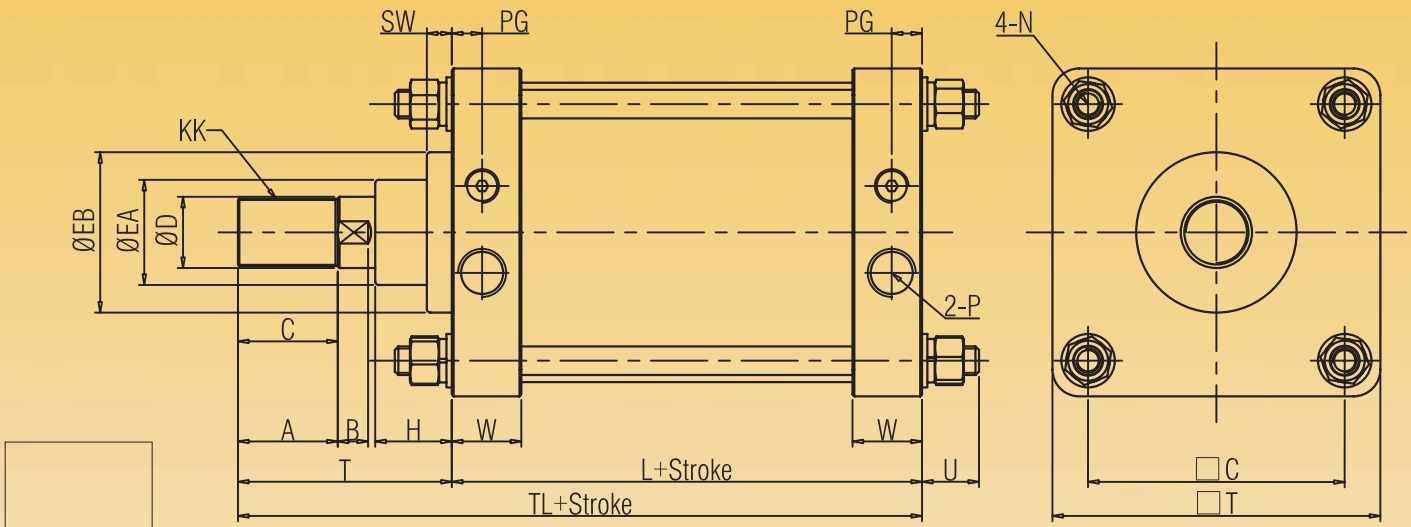

ID(mm)	Stroke Range	C	A	B	□C	ØD	ØEB	ØEA	H	KK
125	~1000	47	50	15	115	35	90	59	43	M30X1.5
140	~1000	47	50	15	128	35	90	59	43	M30X1.5
150	~1200	53	56	17	132	40	90	59	43	M36X1.5
160	~1200	53	56	17	144	40	90	59	43	M36X1.5
180	~1400	60	63	20	162	45	115	70	48	M40X1.5
200	~1600	60	63	20	182	50	115	74	48	M45X1.5
250	~1800	67	71	25	225	60	140	96	60	M56X2.0
300	~2000	76	80	30	270	70	140	96	60	M64X2.0

ID(mm)	N	L	PG	P(PT)	SW	□T	T	TL	U	W
125	M14X1.5	98	16	1/2	14	145	110	208	27	35
140	M14X1.5	98	16	1/2	14	161	110	208	27	35
150	M16X1.5	106	17	3/4	14	170	120	226	30.5	39
160	M16X1.5	106	17	3/4	14	184	120	226	30.5	39
180	M18X1.5	111	17	3/4	17	204	135	246	35	39
200	M20X1.5	111	17	3/4	17	226	135	246	35	39
250	M24X1.5	141	22	1	20	277	160	301	41.5	49
300	M30X1.5	146	23	1	20	330	175	321	51.5	49

# TAN AIR PNEUMATICS

## TPCS1 J.I.S TYPE CYLINDER

### L TYPE FOOT MOUNT

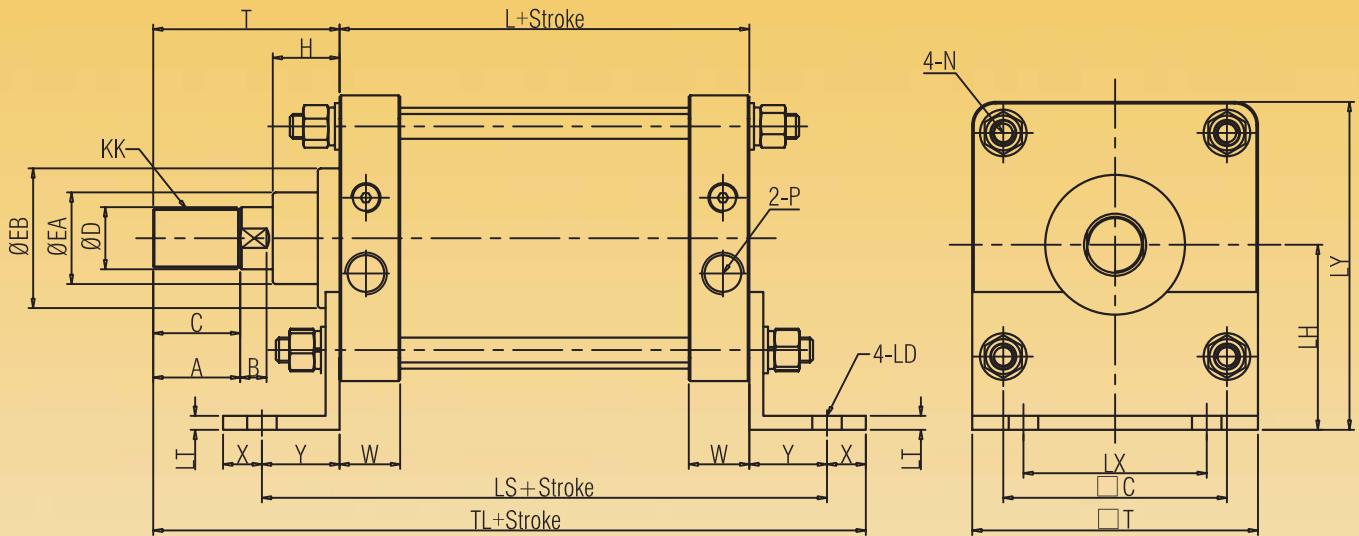

ID(mm)	Stroke Range	C	A	B	□C	ØD	ØEB	ØEA	H	KK	L	ØLD	LH
125	~1000	47	50	15	115	35	90	59	43	M30X1.5	98	19	85
140	~1000	47	50	15	128	35	90	59	43	M30X1.5	98	19	100
150	~1200	53	56	17	132	40	90	59	43	M36X1.5	106	19	105
160	~1200	53	56	17	144	40	90	59	43	M36X1.5	106	19	106
180	~1400	60	63	20	162	45	115	70	48	M40X1.5	111	24	125
200	~1600	60	63	20	182	50	115	74	48	M45X1.5	111	24	132
250	~1800	67	71	25	225	60	140	96	60	M56X2.0	141	29	160
300	~2000	76	80	30	270	70	140	96	60	M64X2.0	146	33	200

ID(mm)	LS	LT	LX	LY	N	P(PT)	□T	T	TL	W	X	Y
125	118	8	100	157.5	M14X1.5	1/2	145	110	273	35	45	20
140	118	9	112	180.5	M14X1.5	1/2	161	110	273	35	45	20
150	206	9	118	190	M16X1.5	3/4	170	120	301	39	50	25
160	206	9	118	197	M16X1.5	3/4	184	120	301	39	50	25
180	231	10	132	227	M18X1.5	3/4	204	135	336	39	60	30
200	231	10	150	245	M20X1.5	3/4	226	135	336	39	60	30
250	301	12	180	298.5	M24X1.5	1	277	160	421	49	80	40
300	326	15	212	365	M30X1.5	1	330	175	451	49	90	40

# TAN AIR PNEUMATICS

## TPCS1 J.I.S TYPE CYLINDER

### F TYPE FRONT FLANGE

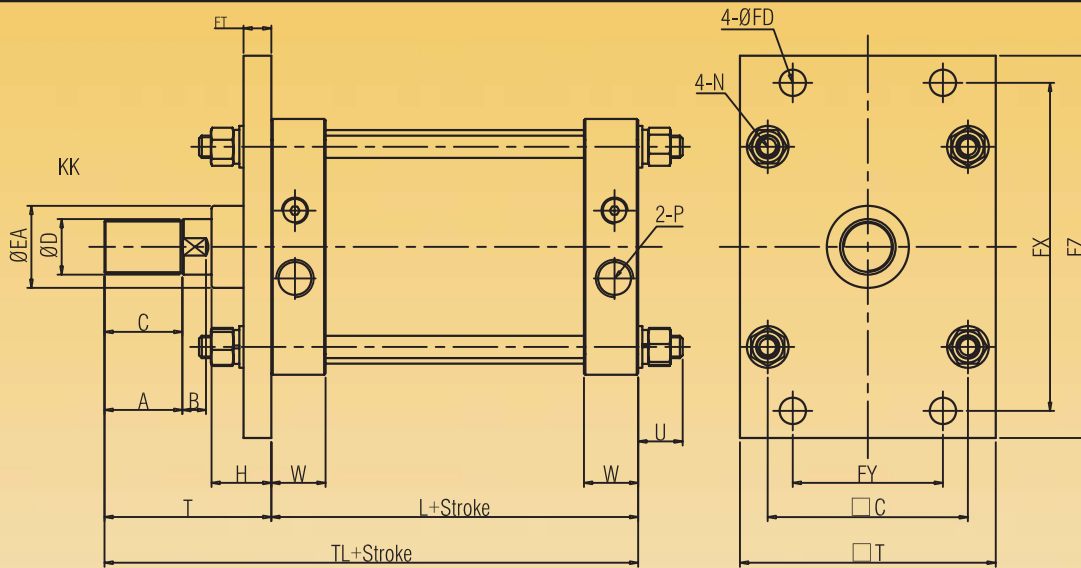

ID(mm)	Stroke Range	C	A	B	□C	ØD	ØEA	H	L	KK
125	~1000	47	50	15	115	35	59	43	98	M30X1.5
140	~1000	47	50	15	128	35	59	43	98	M30X1.5
150	~1200	53	56	17	132	40	59	43	106	M36X1.5
160	~1200	53	56	17	144	40	59	43	106	M36X1.5
180	~1400	60	63	20	162	45	70	48	111	M40X1.5
200	~1600	60	63	20	182	50	74	48	111	M45X1.5
250	~1800	67	71	25	225	60	96	60	141	M56X2.0
300	~2000	76	80	30	270	70	96	60	146	M64X2.0

ID(mm)	N	P(PT)	□T	T	TL	W	ØFD	FT	FX	FY	FZ
125	M14X1.5	1/2	145	110	235	35	19	14	190	100	230
140	M14X1.5	1/2	161	110	235	35	19	20	212	112	255
150	M16X1.5	3/4	170	120	256.5	39	19	20	228	115	265
160	M16X1.5	3/4	184	120	256.5	39	19	20	236	118	275
180	M18X1.5	3/4	204	135	281	39	24	25	265	132	320
200	M20X1.5	3/4	226	135	281	39	24	25	280	150	335
250	M24X1.5	1	277	160	342.5	49	29	30	355	180	420
300	M30X1.5	1	330	175	372.5	49	33	30	400	212	475

# TAN AIR PNEUMATICS

## TPCS1 J.I.S TYPE CYLINDER

### G TYPE REAR FLANGE

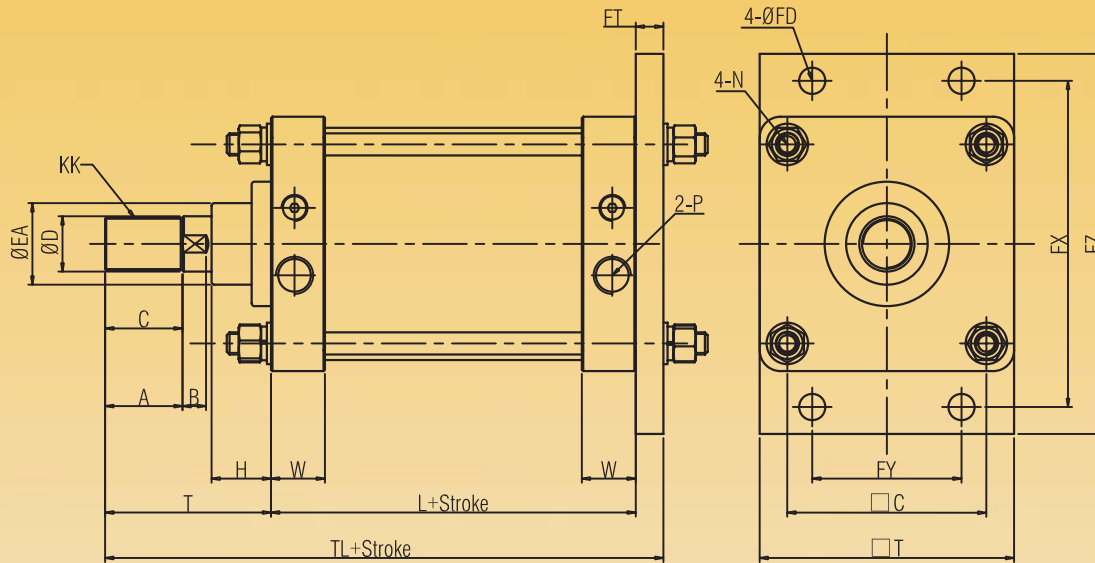

ID(mm)	Stroke Range	C	A	B	□C	ØD	ØEB	ØEA	H	KK
125	~1000	47	50	15	115	35	90	59	43	M30X1.5
140	~1000	47	50	15	128	35	90	59	43	M30X1.5
150	~1200	53	56	17	132	40	90	59	43	M36X1.5
160	~1200	53	56	17	144	40	90	59	43	M36X1.5
180	~1400	60	63	20	162	45	115	70	48	M40X1.5
200	~1600	60	63	20	182	50	115	74	48	M45X1.5
250	~1800	67	71	25	225	60	140	96	60	M56X2.0
300	~2000	76	80	30	270	70	140	96	60	M64X2.0

ID(mm)	N	L	P(PT)	□T	T	TL	W	ØFD	FT	FX	FY	FZ
125	M14X1.5	98	1/2	145	110	222	35	19	14	190	100	230
140	M14X1.5	98	1/2	161	110	228	35	19	20	212	112	255
150	M16X1.5	106	3/4	170	120	246	39	19	20	228	115	265
160	M16X1.5	106	3/4	184	120	246	39	19	20	236	118	275
180	M18X1.5	111	3/4	204	135	271	39	24	25	265	132	320
200	M20X1.5	111	3/4	226	135	271	39	24	25	280	150	335
250	M24X1.5	141	1	277	160	331	49	29	30	355	180	420
300	M30X1.5	146	1	330	175	351	49	33	30	400	212	475

# TAN AIR PNEUMATICS

## TPCS1 J.I.S TYPE CYLINDER

### C TYPE SINGLE REAR CLEVIS

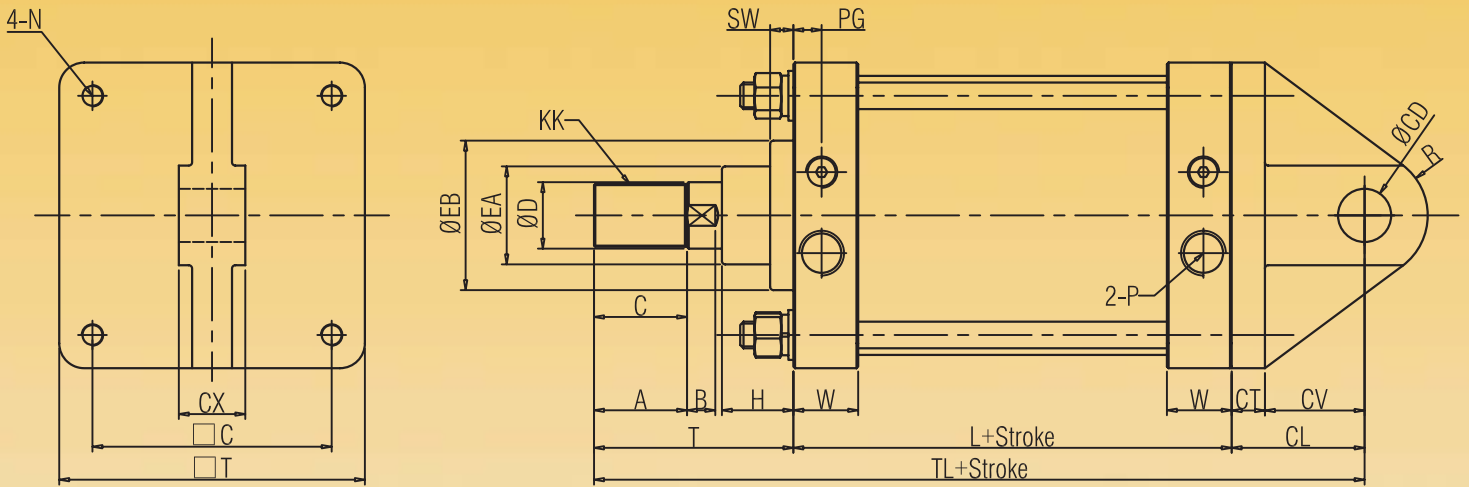

ID(mm)	Stroke Range	C	A	B	□C	ØD	ØEA	ØEB	H	L	KK
125	~1000	47	50	15	115	35	59	90	43	98	M30X1.5
140	~1000	47	50	15	128	35	59	90	43	98	M30X1.5
150	~1200	53	56	17	132	40	59	90	43	106	M36X1.5
160	~1200	53	56	17	144	40	59	90	43	106	M36X1.5
180	~1400	60	63	20	162	45	70	115	48	111	M40X1.5
200	~1600	60	63	20	182	50	74	115	48	111	M45X1.5
250	~1800	67	71	25	225	60	96	140	60	141	M56X2.0
300	~2000	76	80	30	270	70	96	140	60	146	M64X2.0

ID(mm)	N	P(PT)	□T	T	TL	W	ØCD	R	CL	CT	CV	CX
125	M14X1.5	1/2	145	110	273	35	25	29	65	17	48	32
140	M14X1.5	1/2	161	110	283	35	28	32	75	17	58	36
150	M16X1.5	3/4	170	120	306	39	32	36	80	20	60	40
160	M16X1.5	3/4	184	120	306	39	32	36	80	20	60	40
180	M18X1.5	3/4	204	135	336	39	40	44	90	23	67	50
200	M20X1.5	3/4	226	135	336	39	40	44	90	25	75	50
250	M24X1.5	1	277	160	411	49	50	55	110	30	80	63
300	M30X1.5	1	330	175	451	49	63	68	130	37	93	80

# TAN AIR PNEUMATICS

## TPCS1 J.I.S TYPE CYLINDER

### D TYPE DOUBLE REAR CLEVIS

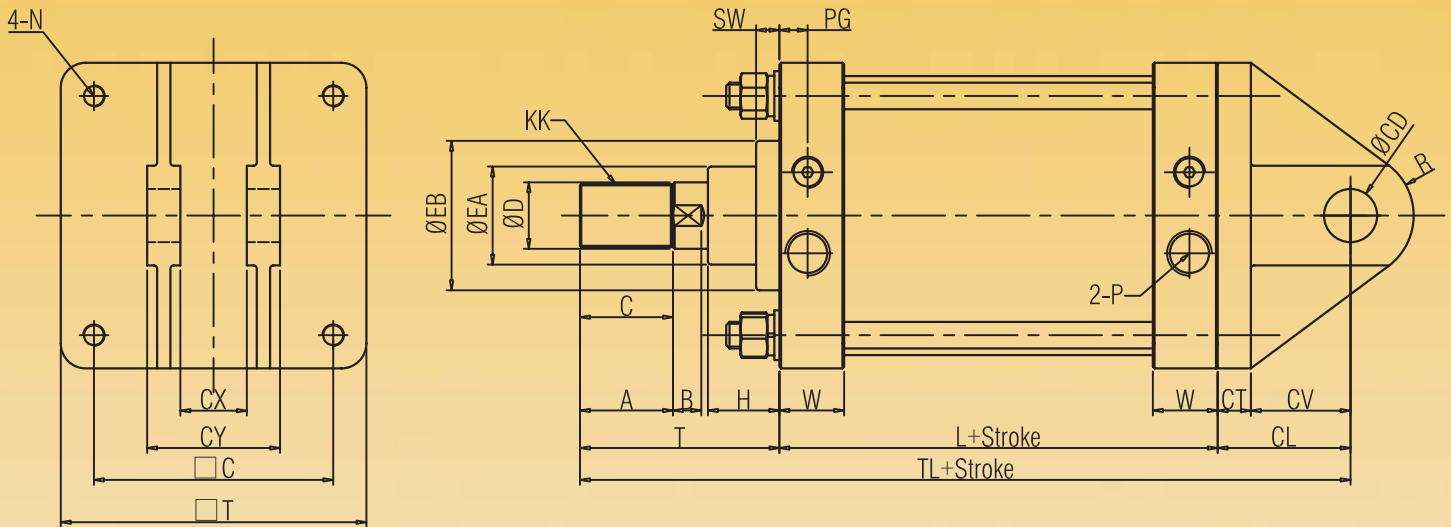

ID(mm)	Stroke Range	C	A	B	□C	ØD	ØEA	ØEB	H	L	KK
125	~1000	47	50	15	115	35	59	90	43	98	M30X1.5
140	~1000	47	50	15	128	35	59	90	43	98	M30X1.5
150	~1200	53	56	17	132	40	59	90	43	106	M36X1.5
160	~1200	53	56	17	144	40	59	90	43	106	M36X1.5
180	~1400	60	63	20	162	45	70	115	48	111	M40X1.5
200	~1600	60	63	20	182	50	74	115	48	111	M45X1.5
250	~1800	67	71	25	225	60	96	140	60	141	M56X2.0
300	~2000	76	80	30	270	70	96	140	60	146	M64X2.0

ID(mm)	N	P(PT)	□T	T	TL	W	ØCD	R	CL	CT	CV	CX	CZ
125	M14X1.5	1/2	145	110	273	35	25	29	65	17	48	64	32
140	M14X1.5	1/2	161	110	283	35	28	32	75	17	58	72	36
150	M16X1.5	3/4	170	120	306	39	32	36	80	20	60	80	40
160	M16X1.5	3/4	184	120	306	39	32	36	80	20	60	80	40
180	M18X1.5	3/4	204	135	336	39	40	44	90	23	67	100	50
200	M20X1.5	3/4	226	135	336	39	40	44	90	25	75	100	50
250	M24X1.5	1	277	160	411	49	50	55	110	30	80	126	63
300	M30X1.5	1	330	175	451	49	63	68	130	37	93	160	80

# TAN AIR PNEUMATICS

## TPCS1 J.I.S TYPE CYLINDER

### T TYPE TRUNION

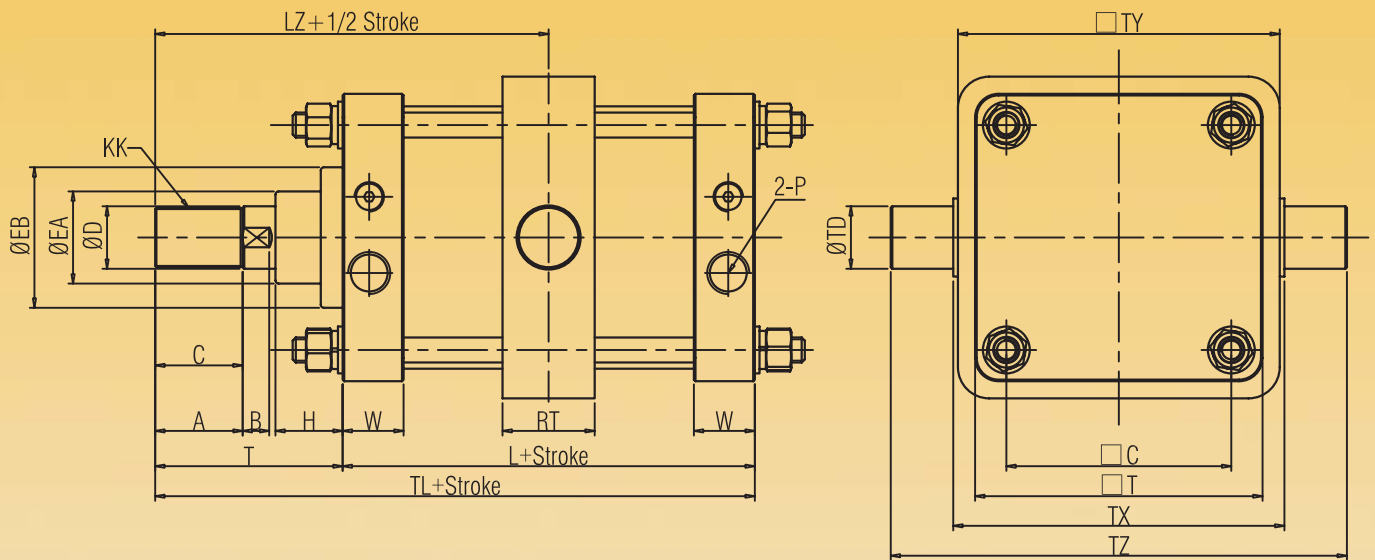

ID(mm)	Stroke Range	C	A	B	□C	ØD	ØEA	ØEB	H	L	KK
125	~1000	47	50	15	115	35	59	90	43	98	M30X1.5
140	~1000	47	50	15	128	35	59	90	43	98	M30X1.5
150	~1200	53	56	17	132	40	59	90	43	106	M36X1.5
160	~1200	53	56	17	144	40	59	90	43	106	M36X1.5
180	~1400	60	63	20	162	45	70	115	48	111	M40X1.5
200	~1600	60	63	20	182	50	74	115	48	111	M45X1.5
250	~1800	67	71	25	225	60	96	140	60	141	M56X2.0
300	~2000	76	80	30	270	70	96	140	60	146	M64X2.0

ID(mm)	N	P(PT)	□T	T	TL	W	ØTD	RT	LZ	TX	□TY	TZ
125	M14X1.5	1/2	145	110	208	35	32	50	159	170	164	234
140	M14X1.5	1/2	161	110	208	35	36	55	159	190	184	262
150	M16X1.5	3/4	170	120	226	39	40	59	173	200	192	275
160	M16X1.5	3/4	184	120	226	39	40	59	173	212	204	292
180	M18X1.5	3/4	204	135	246	39	45	60	190.5	236	228	326
200	M20X1.5	3/4	226	135	246	39	45	60	190.5	265	257	355
250	M24X1.5	1	277	160	301	49	56	69	230.5	335	325	447
300	M30X1.5	1	330	175	321	49	67	79	248	400	390	534

# TAN AIR PNEUMATICS

## TPCS1 J.I.S TYPE CYLINDER

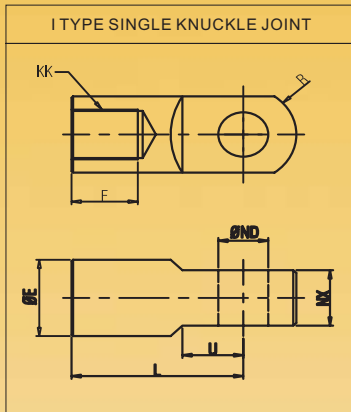

ID(mm)	KK	L	ØE	F	ØND	NX	R	U
125	M30X1.5	100	46	54	25	32	27	33
140	M30X1.5	105	48	54	28	36	30	39
150	M36X1.5	110	55	60	32	40	34	39
160	M36X1.5	110	55	60	32	40	34	39
180	M40X1.5	125	70	67	40	50	42.5	44
200	M45X1.5	125	70	67	40	50	42.5	44
250	M56X2	160	86	75.5	50	63	53	66
300	M64X2	175	105	84.5	63	80	66	71

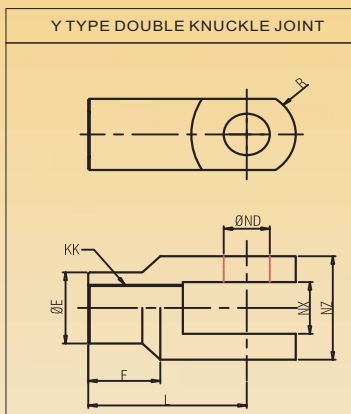

ID(mm)	KK	L	ØE	ØND	NX	NZ	R
125	M30X1.5	100	46	25	32	64	27
140	M30X1.5	105	48	28	36	72	30
150	M36X1.5	110	55	32	40	80	34
160	M36X1.5	110	55	32	40	80	34
180	M40X1.5	125	70	40	50	100	42.5
200	M45X1.5	125	70	40	50	100	42.5
250	M56X2	160	86	50	63	126	53
300	M64X2	175	105	63	80	160	66

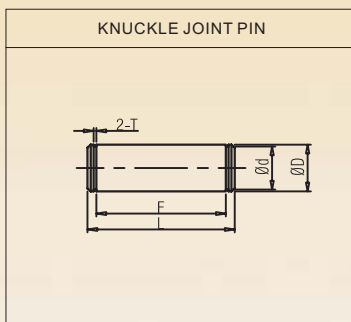

ID(mm)	ØD	Ød	L	F	T
125	25	23.5	72	64.3	1.35
140	28	28	80.6	72.3	1.65
150,160	32	29.5	89.6	80.3	1.65
180,200	40	37	110.1	100.3	1.9
250	50	46	138.9	126.5	2.2
300	63	59	172.9	160.5	2.2

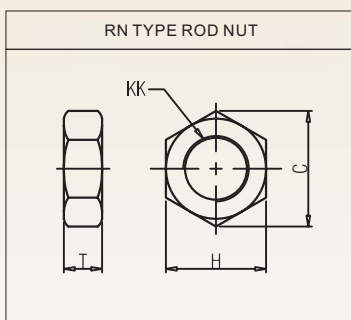

ID(mm)	KK	C	H	T
125,140	M30X1.5	53.1	46	18
150,160	M36X1.5	63.5	55	21
180	M40X1.5	69.3	60	23
200	M45X1.5	80.8	70	27
250	M56X2	98.1	85	34
300	M64X2	110	95	38